

TEST REPORT

Rendered to:

KEYLINK FENCING & KENNELS

For:

Structural Post Mounts

Report No: 94575.01-119-19
Report Date: 09/23/09

TEST REPORT

94575.01-119-19
September 23, 2009

TABLE OF CONTENTS

1.0 General Information.....	1
1.1 Product.....	1
1.2 Project Description	1
1.3 Limitations.....	1
1.4 Qualifications.....	1
1.5 Product Description	2
1.6 Witnessing	2
1.7 Conditions of Testing	2
2.0 Structural Performance Testing of Assembled Railing Systems	2
2.1 Test Equipment.....	2
2.2 Test Setup	2
2.3 Test Procedure	3
2.4 Test Results.....	3
2.5 Summary and Conclusions	4
3.0 Closing Statement	5
Revision Log.....	6
Appendix A - Drawings	
Appendix B - Photographs	

TEST REPORT

Rendered to:

KEYLINK FENCING & KENNELS
150 Orlan Road
New Holland, Pennsylvania 17557

Report No.: 94575.01-119-19
Test Date: 09/14/09
Report Date: 09/23/09

1.0 General Information

1.1 Product

Structural Post Mounts

1.2 Project Description

Architectural Testing was contracted by Keylink Fencing & Kennels to conduct structural performance tests on the 38 in and 48 in high by 2-1/2 in square, surface mounted structural post mounts. The system was evaluated for the design load requirements of the following building codes:

2009 International Building Code[®], International Code Council

2009 International Residential Code[®], International Code Council

Structural tests were performed according to Chapter 17 (Structural Tests and Special Inspections) of the *2009 International Building Code*[®].

1.3 Limitations

Anchorage of support posts to the supporting structure is not included in the scope of this testing and would need to be evaluated separately. Evaluation of the base mounting hardware is not within the scope of these tests.

1.4 Qualifications

Architectural Testing has demonstrated compliance with ANS/ISO/IEC Standard 17025 and is consequently accredited as a Testing Laboratory (TL-144) by International Accreditation Service, Inc.

1.5 Product Description

The structural post mount consisted of a 2-1/2 in square, 6063-T6 aluminum tube with a 0.125 in wall thickness, welded to a 3-7/8 in square by 3/8 in or 1/2 in thick 6063-T6 aluminum base plate. The base plate consisted of five 3/8 in diameter thru holes (one in the center of the plate) for mounting and four 3/8-16 UNC holes for leveling purposes.

See drawings in Appendix A and photographs in Appendix B for additional details.

1.6 Witnessing

A representative of Keylink Fencing & Kennels was present on September 14, 2009, to witness the structural performance testing of assembled railing systems.

1.7 Conditions of Testing

Unless otherwise indicated, all testing reported herein was conducted in a laboratory set to maintain temperature in the range of $68 \pm 4^{\circ}\text{F}$ and humidity in the range of $50 \pm 5\% \text{ RH}$.

2.0 Structural Performance Testing of Assembled Railing Systems

2.1 Test Equipment

The post mounts were tested in a self-contained structural frame designed to accommodate anchorage of the post mount assembly and application of the required test loads. The specimens were loaded using an electric winch mounted to a rigid steel test frame. High strength steel cables and nylon straps were used to impose test loads on the specimens. Applied load was measured using an electronic load cell located in-line with the loading system. Electronic linear motion transducers were used to measure deflections.

2.2 Test Setup

The structural post mounts were directly secured into the surface of a rigid steel channel (to simulate anchorage into concrete) with four 5/16 in Grade 5 bolts. A transducer was mounted to an independent reference frame and was located to record movement of a reference point on the post mount to determine the post deflection. See photographs in Appendix B for individual test setups.

2.3 Test Procedure

Each test specimen was inspected prior to testing to verify size and general condition of the materials, assembly, and installation. No potentially compromising defects were observed prior to testing. An initial load, not exceeding 50% of design load, was applied and transducers were zeroed. Load was then applied at a steady uniform rate until reaching 2.0 times design load in no less than 10 seconds. After reaching 2.0 times design load, the load was released. After allowing a minimum period of one minute for stabilization, load was reapplied to the initial load level used at the start of the loading procedure, and deflections were recorded and used to analyze recovery. Load was then increased at a steady uniform rate until reaching 2.5 times design load or until failure occurred. The testing time was continually recorded from the application of initial test load until the ultimate test load was reached.

2.4 Test Results

The following tests were performed on the structural post mounts for the design load requirements of the codes referenced. Deflection and permanent set were component deflections relative to the top of the post; they were not overall system displacements. All loads and displacement measurements were horizontal, unless noted otherwise.

Key to Test Results Tables:

Load Level: Target test load

Test Load: Actual applied load at the designated load level (target). Where more than one value is reported, the test load was the range (min.-max.) that was held during the time indicated in the test.

Elapsed Time (E.T.): The amount of time into the test with zero established at the beginning of the loading procedure. Where more than one value is reported, the time was the range (start-end) that the designated load level was reached and sustained.

Test No. 1 - 48 in High by 2-1/2 in Square Structural Post Mount with 3/8 in Base Plate			
Design Load: 200 lb Concentrated Load at Top of a Single Post¹ at a Height of 42 in			
Load Level	Test Load (lb)	E.T. (min:sec)	Post Displacement (in)
Initial Load	49	00:00	0.00
2.0x Design Load	400	01:08	2.23
Initial Load	50	03:15	0.71
68% Recovery from 2.0 x Design Load			
2.5x Design Load	501	04:20	<i>Maximum Test Load - Achieved without failure</i>

¹ Post was conservatively tested without a guardrail system attached

2.4 Test Results (Continued)

Test No. 2 - 48 in High by 2-1/2 in Square Structural Post Mount with 1/2 in Base Plate			
Design Load: 200 lb Concentrated Load at Top of a Single Post¹ at a Height of 42 in			
Load Level	Test Load (lb)	E.T. (min:sec)	Post Displacement (in)
Initial Load	51	00:00	0.00
2.0x Design Load	400	00:31	1.99
Initial Load	54	03:07	0.57
71% Recovery from 2.0 x Design Load			
2.5x Design Load	502	03:56	<i>Maximum Test Load - Achieved without failure</i>

¹ Post was conservatively tested without a guardrail system attached

Test No. 3 - 38 in High by 2-1/2 in Square Structural Post Mount with 3/8 in Mounting Plate			
Design Load: 200 lb Concentrated Load at Top of a Single Post¹ at a Height of 36 in			
Load Level	Test Load (lb)	E.T. (min:sec)	Post Displacement (in)
Initial Load	50	00:00	0.00
2.0x Design Load	403	00:53	1.22
Initial Load	55	03:33	0.29
77% Recovery from 2.0 x Design Load			
2.5x Design Load	502	04:22	<i>Maximum Test Load - Achieved without failure</i>

¹ Post was conservatively tested without a guardrail system attached

2.5 Summary and Conclusions

Using performance criterion of withstanding an ultimate load of 2.5 times design load, the test results substantiate compliance with the design load requirements of the referenced building codes for the structural post mounts reported herein.

3.0 Closing Statement

Detailed drawings, data sheets, representative samples of test specimens, a copy of this test report, and all other supporting evidence will be retained by Architectural Testing for a period of four years from the original test date. At the end of this retention period, said materials shall be discarded without notice, and the service life of this report by Architectural Testing shall expire. Results obtained are tested values and were secured using the designated test methods. This report neither constitutes certification of this product nor expresses an opinion or endorsement by this laboratory; it is the exclusive property of the client so named herein and relates only to the tested specimens. This report may not be reproduced, except in full, without the written approval of Architectural Testing.

For ARCHITECTURAL TESTING:

Keith A. Gurnee
Technician II
Structural Systems Testing

Justin M. Mann
Laboratory Supervisor
Structural Systems Testing

KAG:jmm/alb

Attachments (pages): This report is complete only when all attachments listed are included.

Appendix A: Drawings (2)

Appendix B: Photographs (1)

Revision Log

<u>Rev. #</u>	<u>Date</u>	<u>Page(s)</u>	<u>Revision(s)</u>
0	09/23/09	N/A	Original report issue

APPENDIX A

Drawings

2.5 x 38" post

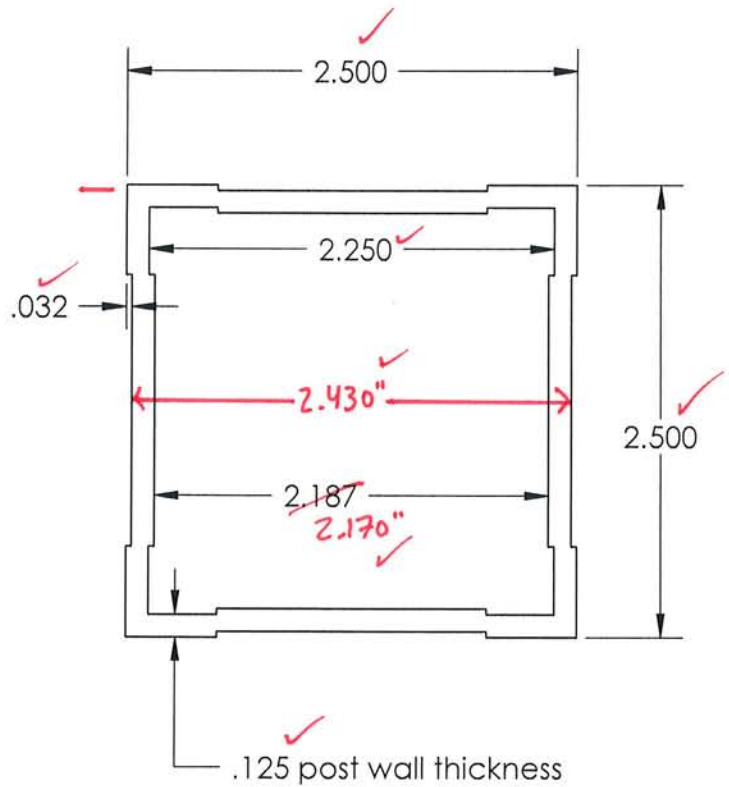

0.390"
.375
(OR) 0.500"

* 0.160-0.300

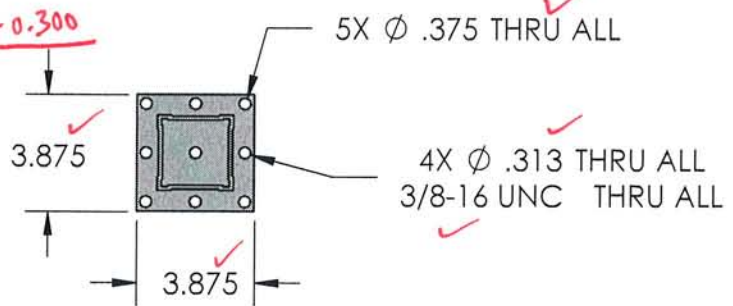

Architectural Testing

Test sample complies with these details.
Deviations are noted.

Report# 94575.01-119-19

Date 9/22/09 Tech JMM



MATERIAL ALUMINUM
FINISH

DO NOT SCALE DRAWING

* NOTE: Welds vary in thickness and cannot be properly classified. Drawings depict weld thickness range as measured.

NAME Elmer DATE 9/16/2008
DRAWN
CHECKED
ENG APPR.
MFG APPR.
Q.A.
COMMENTS

Superior Plastic

2.5 welded posts

SIZE DWG. NO. A
SCALE: 1:6 WEIGHT:

REV.

SHEET 1 OF 4

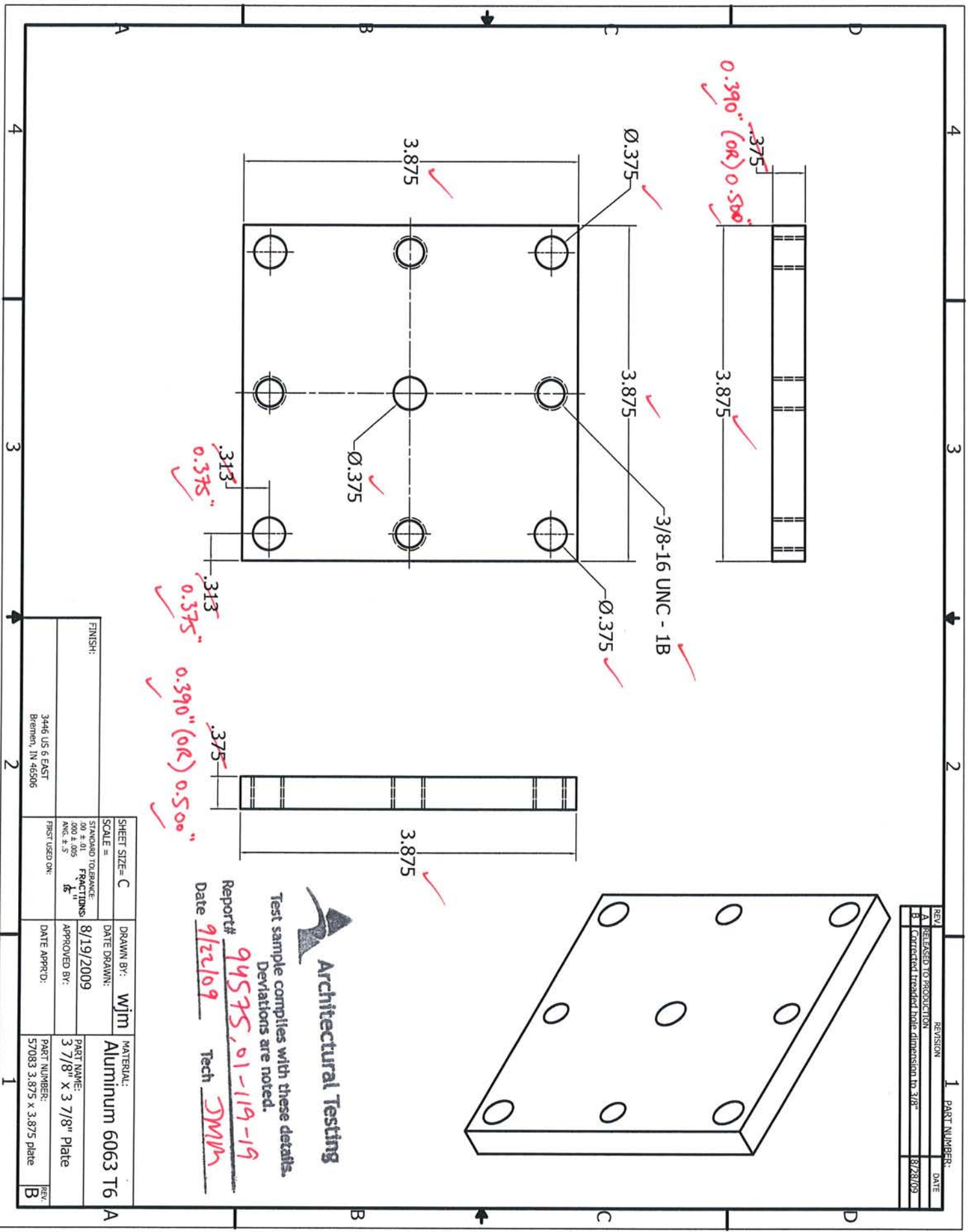

REV	REVISION	DATE
A	RELEASED TO PRODUCTION	8/28/09
B	Corrected threaded hole dimension to .318"	

PART NUMBER: 57083



Architectural Testing

Test sample complies with these details.
Deviations are noted.

Report# 94575.01-19-19
Date 9/22/09 Tech DMW

SHEET SIZE= C	DRAWN BY: wjm	MATERIAL: Aluminum 6063 T6
SCALE =	DATE DRAWN: 8/19/2009	PART NAME: 3 7/8" X 3 7/8" Plate
STANDARD TOLERANCE: .00 ± .01	APPROVED BY:	PART NUMBER: 57083 3.875 x 3.875 plate
FRACTIONS: 16"	DATE APPRD:	REV: B
ANGS: ± .5°		
FIRST USED ON:		

FINISH: 3446 US 6 EAST
Bremen, IN 46506

4 3 2 1

A B C D

APPENDIX B

Photographs



Photo No. 1
Concentrated Load at Top of a Single Post Test Setup

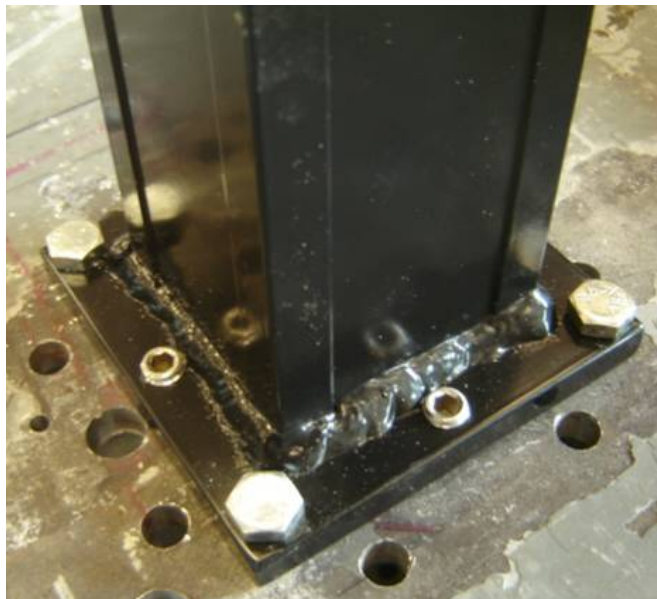

Photo No. 2
Simulated Concrete Condition